



metcon
SALES & ENGINEERING LTD.



Dry Chemical Feed



Powder Technology

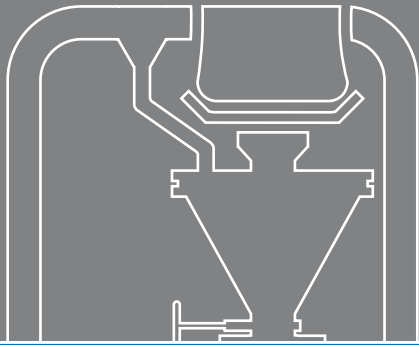

With over 25 years of manufacturing experience in Water and Wastewater Systems, Metcon Sales & Engineering Ltd. has established a reputation as a market leader in Chemical Feed and Disinfection Systems.

Metcon Sales & Engineering Ltd. offers a variety of pre-engineered, fabricated dry chemical feed packages. Each system is custom designed to meet the unique needs of existing and new treatment facilities. With our manufacturing and engineering capabilities, minimal field assembly and piping installation is required.

Various chemical feed system configurations are available depending on plant requirements. For smaller applications, simple bag unloaders and tank/hopper assemblies are ideal. For larger applications, Metcon can supply complete bulk bag and silo configurations. Solution and slurry make-up can be provided for a variety of control strategies (manual, semi-automatic, or completely automatic).

A facility's floor space and manpower, the amount of chemical required and the availability of the chemical are key factors to consider when designing a system. Metcon is available for consultation no matter what the requirements.

Dry Feed System Options

- Continuous batch make-up
- Small bags into hopper / dust collector
- Manual shaking of bags in dust collector
- Hopper c/w vibrator, level control, isolation
- Volumetric feeder / DC drive
- Vary speed to vary concentration
- Control pump to vary dosage
 - Fixed concentration, vary solution feed rate
- SS or PE tank with mixer
- Level control
- Dust arrestor
- From tanks
 - Diaphragm metering pumps
 - Peristaltic metering pumps
 - Gear and centrifugal pumps
 - Gravity feed





metcon
SALES & ENGINEERING LTD.



Dry Chemical Feed



Bulk Bag Unloader

The bulk bag unloader comes complete on a free standing frame. The package is supplied with a lower bag flow actuator, level control in a transition hopper, and a bag access door connected to a dust collector.

The system is situated on top of the solution make up package complete with feeder, tank, mixer, control panel, and metering pumps.

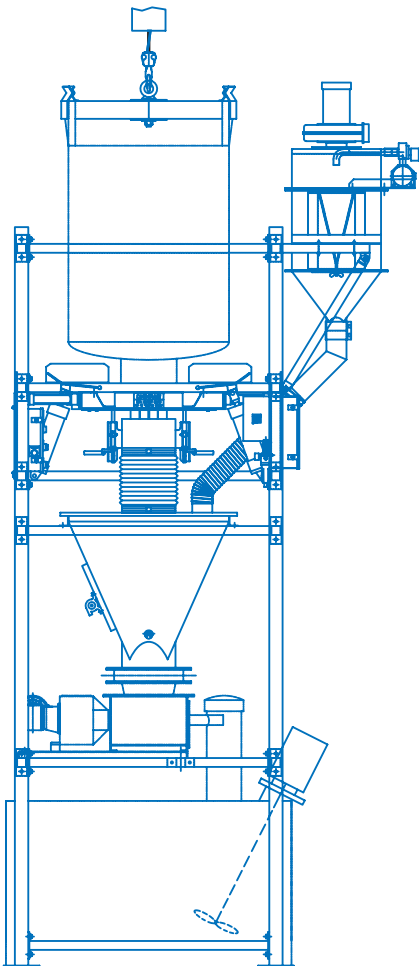

PAC Powder Activated Carbon

The compact and sturdy/steel design of Metcon's PAC Feed Systems allow it to fit into any operation using only a small footprint. The steel construction ensures lifetime structural security. Our systems use Super Bag Technology in an automated process, eliminating slurry handling.

Our PAC feed systems are available in completely dust free assemblies, enabling an environmentally clean and operator friendly operation. Plus the Volumetric Feeders not only assure both positive flow and feed, but also maintain total control of the product for an unsurpassed level of performance.

Features

- Compact design and sturdy
- Continuous operation
- No dust
- No slurry handling
- Little field erection
- Large storage capacity
- Small foot print
- No slurry tank, mixer or metering pumps
- Low mess, low maintenance



Silo Systems

Bulk Storage & Dosing Systems

The silo system includes a complete chemical dry bulk storage and dosing system. Installation drawings and instructions, installation inspection, start up and commissioning, and customer training with respect to operation, maintenance and safety precautions, are offered standard with each system.

Chemical is pneumatically unloaded from the truck trailer, utilizing the truck's compressor and hoses for connection to a filling pipe. A bin vent filter cleaning cycle automatically engages when the fill the cycle begins.

The silo is welded steel construction with a full support skirt. It comes equipped with a fill line, safety ladders and guardrails, level control, lights, heaters, vent filters, control panels, and slurry or solution make up Systems.

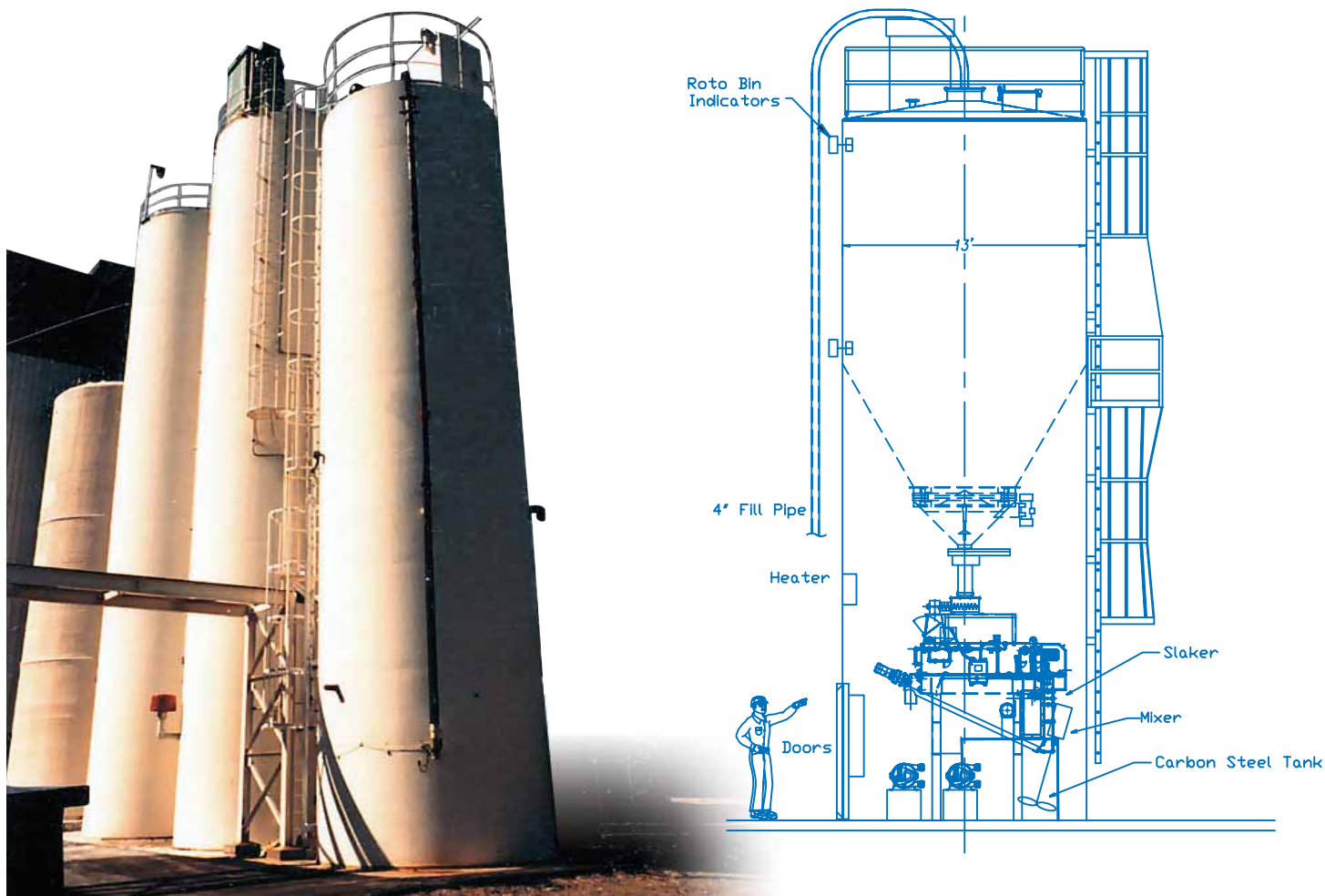

Metcon Sales & Engineering Ltd.

15 Connie Crescent, Unit 3
Concord, Ontario, Canada L4K 1L3
T • 905.738.2355
F • 905.738.5520

E • metcon@metconeng.com
www.metconeng.com

